

StellairTM Air Spray Gun

3B0141D

EN

Air spray gun for fine finish application of select paints and coatings using a properly regulated air source. For professional use only.

300 psi (2.1 MPa, 21 bar) maximum working fluid pressure.
100 psi (0.7 MPa, 7 bar) maximum working air pressure.



Important Safety Instructions

Read all warnings and instructions in this manual before using the equipment. Be familiar with the proper control and usage of the equipment. Save these instructions.

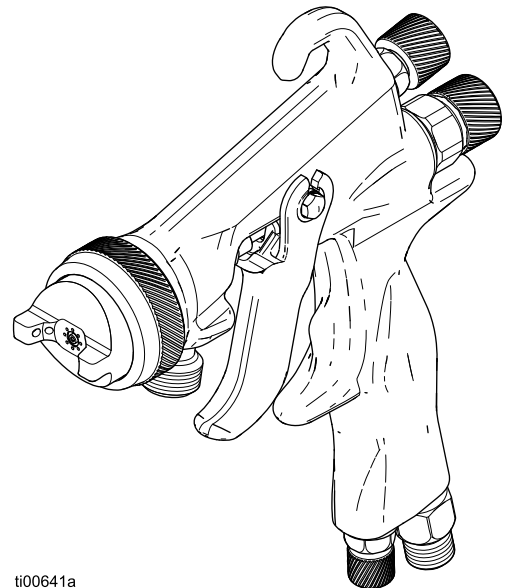

ti00641a

Contents

Models	3
Safety Symbols	4
General Warnings	5
Main Air and Fluid Line Installation	7
Main Air Line Typical Installation	7
Main Fluid Line Typical Installation	7
Setup	8
Ventilate the Spray Booth	8
HVLP Gun Limits	8
Grounding	8
Flush Before Using	8
Connect the Spray Gun	9
Position the Air Cap	10
Adjust Spray Pattern	10
Operation	13
Pressure Relief Procedure	13
Spray Finishing Application	13
Maintenance	14
Flushing Procedure	14
Daily Cleaning Procedure	15
Recycling and Disposal	16
End of Product Life	16
Troubleshooting	17
Spray Pattern Troubleshooting	17
General Troubleshooting	18
Repair	19
Prepare Equipment for Service	19
Fluid Cartridge Repair	19
Fluid Control Valve Repair	22
Fan Control Valve Repair	22
Air Inlet Valve Repair	23
Parts	24
Kits and Accessories	26
Repair Kits	26
Needle Assembly Kits	26
Fluid Cartridge Kits	26
Air Cap Kits	27
Spray Component Kits	28
Needle Tips	29
Hoses	29
Fluid Caps	30
Test Gauges	30
Baffle Kit	30
Light-Weight Lubricant	30
Air Valves and Regulators	31

Cups	31
Technical Specifications	32
Graco Standard Warranty	34

Approvals



NOTE: Type of protection “h” applied is constructional safety “c”.

Spray Technology

Conventional: Optimized for excellent finish quality and high production rates.

HVLP: High transfer efficiency gun that limits the air pressure at the air cap to 10 psi (0.07 MPa, 0.7 bar) maximum.

Compliant: High transfer efficiency gun with a transfer efficiency greater than or equal to HVLP guns.

Applications

Operate all guns from delivery systems, such as pressure pots or remote pumps.

General Industry: Sprays most industrial coatings or finishes used for industrial, automotive, aerospace, marine, wood, plastic, and architectural applications.

Adhesive: Designed for spraying waterborne and solventborne adhesives and sealants.

Trim Air Cap: For a well-defined edge with minimal overspray that’s required for narrow parts spraying including edges and trim pieces.

Wide Pattern Air Cap: For large areas and high productivity with a spray pattern width of a maximum 24in. (0.6 m).

High Solids Air Cap: For maintaining production speed with low VOC and high solids materials.

Wood Air Cap: Designed for low viscosity materials used in wood finishing applications.

Automotive: Designed to atomize with a Class A Finish.

Waterborne: Designed for waterborne materials with high solids content.

Models

Gun Models

Application	Nozzle Size in. (mm)	Tip Construction	Spray Technology		
			Conventional	HVLP	Compliant
General Industry	0.030 (0.8)	PEEK Tip	2004146	2006145	—
	0.042 (1.1)	PEEK Tip	2004147	2004151	2004154
	0.055 (1.4)	PEEK Tip	2004145	2004152	2004155
		SST Tip	2004157	2004159	2004161
	0.070 (1.8)	PEEK Tip	2004148	2004153	2004156
		SST Tip	2004158	2004160	2004162
	0.086 (2.2)	PEEK Tip	2004149	2006146	2006148
0.110 (2.8)	PEEK Tip	2004150	2006147	2006149	
Automotive	0.042 (1.1)	SST Tip	2004163	—	—
	0.055 (1.4)	PEEK Tip	—	2004165	2004166
		SST Tip	2004164	—	—
High Solids*	0.059 (1.5)	High Wear	2006152	—	2006153
	0.070 (1.8)	High Wear	2004167	2004169	2004171
	0.086 (2.2)	High Wear	2004168	2004170	2004172
Adhesives	0.051 (1.3)	PEEK Tip	2004173	—	—
	0.070 (1.8)	PEEK Tip	2004174	—	—
Trim	0.042 (1.1)	PEEK Tip	—	2004175	—
	0.055 (1.4)	PEEK Tip	—	2004176	—
Waterborne	0.042 (1.1)	PEEK Tip	2006151	—	—
	0.055 (1.4)	SST Tip	2004177	—	—
Wood	0.040 (1.0)	PEEK Tip	2004178	2004179	—
	0.040 (1.0)	PEEK Tip	—	2006150**	—
Wide Pattern	0.055 (1.4)	PEEK Tip	2004180	2004182	2004184
	0.070 (1.8)	PEEK Tip	2004181	2004183	2004185





* High Solids gun models include high wear (Elite) packing, carbide needle, and carbide nozzle tip.

** Wood air cap with non-adjustable fluid needle.

Safety Symbols

The following safety symbols appear throughout this manual and on warning labels. Read the table below to understand what each symbol means.

Symbol	Meaning
	Equipment Misuse Hazard
	Fire and Explosion Hazard
	Pressurized Equipment Hazard
	Splash Hazard
	Toxic Fluid or Fumes Hazard
	Eliminate Ignition Sources

Symbol	Meaning
	Follow Pressure Relief Procedure
	Ground Equipment
	Read Manual
	Ventilate Work Area
	Wear Personal Protective Equipment







Safety Alert Symbol

This symbol indicates: Attention! Become Alert! Look for this symbol throughout the manual to indicate important safety messages.

General Warnings

The following warnings apply throughout this manual. Read, understand, and follow the warnings before using this equipment. Failure to follow these warnings can result in serious injury.

 WARNING	
	<p>FIRE AND EXPLOSION HAZARD</p> <p>Flammable fumes, such as solvent and paint fumes, in work area can ignite or explode. Paint or solvent flowing through the equipment can cause static sparking. To help prevent fire and explosion:</p> <ul style="list-style-type: none"> • Use equipment only in well-ventilated area. • Eliminate all ignition sources; such as pilot lights, cigarettes, portable electric lamps, and plastic drop cloths (potential static sparking). • Ground all equipment in the work area. See Grounding, instructions. • Never spray or flush solvent at high pressure. • Keep work area free of debris, including solvent, rags and gasoline. • Do not plug or unplug power cords, or turn power or light switches on or off when flammable fumes are present. • Use only grounded hoses. • Hold gun firmly to side of grounded pail when triggering into pail. Do not use pail liners unless they are anti-static or conductive. • Stop operation immediately if static sparking occurs or you feel a shock. Do not use equipment until you identify and correct the problem. • Keep a working fire extinguisher in the work area.
	<p>PRESSURIZED EQUIPMENT HAZARD</p> <p>Fluid from the equipment, leaks, or ruptured components can splash in the eyes or on skin and cause serious injury.</p> <ul style="list-style-type: none"> • Follow the Pressure Relief Procedure when you stop spraying/dispensing and before cleaning, checking, or servicing equipment. • Tighten all fluid connections before operating the equipment. • Check hoses, tubes, and couplings daily. Replace worn or damaged parts immediately.
	<p>TOXIC FLUID OR FUMES HAZARD</p> <p>Toxic fluids or fumes can cause serious injury or death if splashed in the eyes or on skin, inhaled, or swallowed.</p> <ul style="list-style-type: none"> • Read Safety Data Sheets (SDSs) to know the specific hazards of the fluids you are using. • Store hazardous fluid in approved containers, and dispose of it according to applicable guidelines.

WARNING



EQUIPMENT MISUSE HAZARD

Misuse can cause death or serious injury.



- Do not operate the unit when fatigued or under the influence of drugs or alcohol.
- Do not exceed the maximum working pressure or temperature rating of the lowest rated system component. See **Technical Specifications** in all equipment manuals.
- Use fluids and solvents that are compatible with equipment wetted parts. See **Technical Specifications** in all equipment manuals. Read fluid and solvent manufacturer's warnings. For complete information about your material, request Safety Data Sheets (SDSs) from distributor or retailer.
- Do not leave the work area while equipment is energized or under pressure.
- Turn off all equipment and follow the **Pressure Relief Procedure**, when equipment is not in use.
- Check equipment daily. Repair or replace worn or damaged parts immediately with genuine manufacturer's replacement parts only.
- Do not alter or modify equipment. Alterations or modifications may void agency approvals and create safety hazards.
- Make sure all equipment is rated and approved for the environment in which you are using it.
- Use equipment only for its intended purpose. Call your distributor for information.
- Route hoses and cables away from traffic areas, sharp edges, moving parts, and hot surfaces.
- Do not kink or over bend hoses or use hoses to pull equipment.
- Keep children and animals away from work area.
- Comply with all applicable safety regulations.



PERSONAL PROTECTIVE EQUIPMENT

Wear appropriate protective equipment when in the work area to help prevent serious injury, including eye injury, hearing loss, inhalation of toxic fumes, and burns. Protective equipment includes but is not limited to:

- Protective eyewear, and hearing protection.
- Respirators, protective clothing, and gloves as recommended by the fluid and solvent manufacturer.

Main Air and Fluid Line Installation

Main Air Line Typical Installation

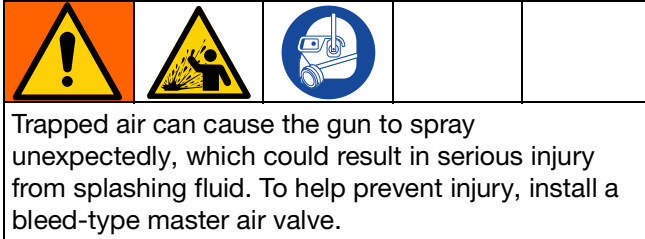

- **Bleed-type master air valve:** required in your system to relieve air trapped between the pump and the gun when the valve is closed.

NOTE: Be sure the valve is easily accessible from the pump and located downstream from the air regulator.

- **Pump air pressure regulator:** to control pump speed and fluid outlet pressure. Locate it close to the pump.
- **Air line filter:** removes harmful dirt and moisture from compressed air supply. Ensures a dry, clean air supply.
- **Air shutoff valve:** shuts off air to the gun and pump.

Main Fluid Line Typical Installation

- **Fluid filter:** with a 60 or 100 mesh (250 micron) stainless steel element to filter particles from the fluid as it leaves the pump. Always use a clean fluid filter.
- **Fluid drain valve:** relieves fluid pressure in the hose and gun. Required in your system to assist in relieving fluid pressure in the displacement pump, hose and gun; triggering the gun to relieve pressure may not be sufficient.
- **Fluid shutoff valve:** shuts off fluid flow. Can be installed in the fluid line to the gun.
- **Fluid pressure regulator:** for more precise adjustment of the fluid pressure. Install a fluid pressure regulator on the main fluid line if the pump's maximum working pressure exceeds the gun's maximum fluid working pressure. See **Technical Specifications**, page 32.

Setup

Ventilate the Spray Booth



Do not operate the gun unless ventilating air flow is above the minimum required value. Provide fresh air ventilation to avoid the buildup of flammable or toxic vapors when spraying, flushing, or cleaning the gun. Interlock the gun fluid supply to prevent operation unless ventilating air flow is above the minimum required value.

The spray booth must have a ventilation system.

Electrically interlock the gun fluid supply with the ventilators to prevent gun operation any time that the ventilation air flow falls below minimum values. Check and follow all local codes and regulations regarding air exhaust velocity requirements. Verify the operation of the interlock at least once a year.

HVLP Gun Limits

In some areas, an HVLP gun is required for compliance with environmental standards. To comply with HVLP requirements, the air pressure at the air cap must be less than 10 psi (0.07 MPa, 0.7 bar).

Grounding



The equipment must be grounded to reduce the risk of static sparking. Static sparking can cause fumes to ignite or explode. Grounding provides an escape wire for the electric current.

The following grounding instructions are minimum requirements for a system. Your system may include other equipment or objects that must be grounded. Check your local electrical code for detailed grounding instructions for your area and type of equipment. Your system must be connected to a true earth ground.

Spray Gun: Ground the spray gun through connection to a properly grounded air and fluid supply hoses and pump. Check your local electrical code and pump manual for detailed grounding instructions. Use only electrically conductive air and fluid hoses.

Pump: Ground the pump by connecting a ground wire and clamp between the pump and a true earth ground as instructed in your separate pump instruction manual.

Air Compressors and Hydraulic Power Supplies: Ground air compressors and hydraulic power supplies according to the manufacturer recommendations.

Air, Fluid, and Hydraulic Hoses Connected To Pump: Use only electrically conductive hoses with a maximum of 100 ft (30.5 m) combined hose length to ensure grounding continuity. Check the electrical resistance of your air and fluid hoses at least once a week. If the total resistance to ground exceeds 25 megohms, replace the hose immediately. Use a meter that is capable of measuring resistance at this level.

Fluid Supply Container: Ground the fluid supply container according to local code and regulations.

Object Being Sprayed: Ground the object that is being sprayed according to local code and regulations.

Solvent Pails: Ground all solvent pails used during the **Flushing Procedure** according to local code. Use only metal pails, which are conductive. Do not place the pail on a non-conductive surface, such as paper or cardboard, which interrupts the grounding continuity.

Flush Before Using

The equipment was tested with lightweight oil, which is left in the fluid passages to protect parts. To avoid contaminating your fluid with oil, flush the equipment with a compatible solvent before using the equipment. See **Flushing Procedure**, page 14.

Connect the Spray Gun

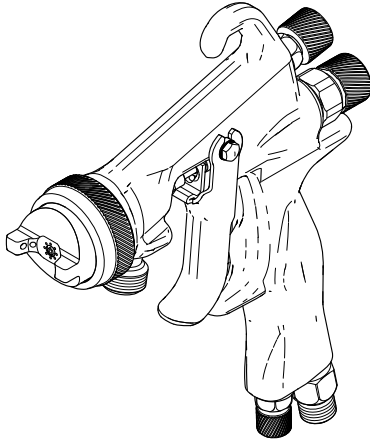

ti00641a

FIG. 1: Gun Air and Hose Connections

1. Connect the gun air supply hose to the gun air inlet (6). A 5/16 in. (7.9 mm) ID hose recommended. A 3/8 in. (9.5 mm) hose is optional.

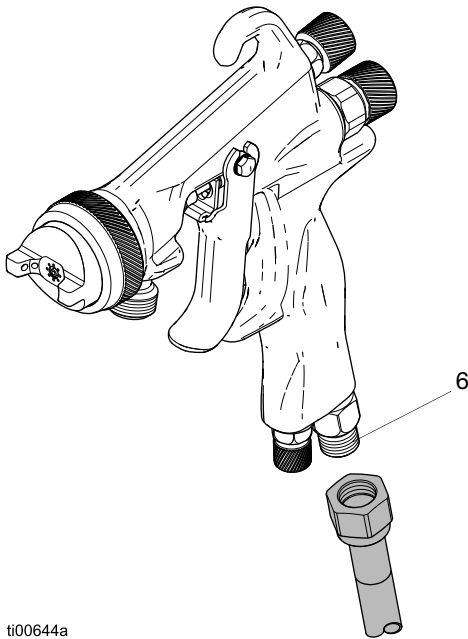

ti00644a

FIG. 2: Connect air hose to gun

2. Connect the other end of the gun air supply hose to the gun air pressure regulator or the air shutoff valve outlet.

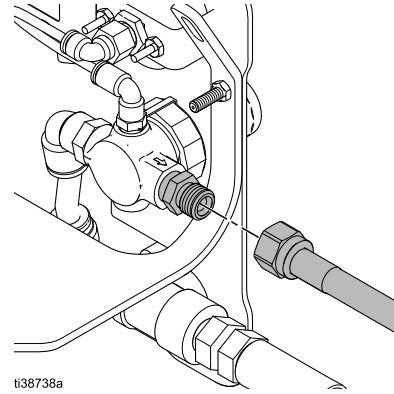

ti38738a

FIG. 3: Connect air hose to gun air pressure regulator

NOTE: Blow air through the gun fluid supply hose and flush it with a compatible solvent before connecting to the gun.

3. Connect the gun fluid supply hose to the fluid inlet fitting (1b).

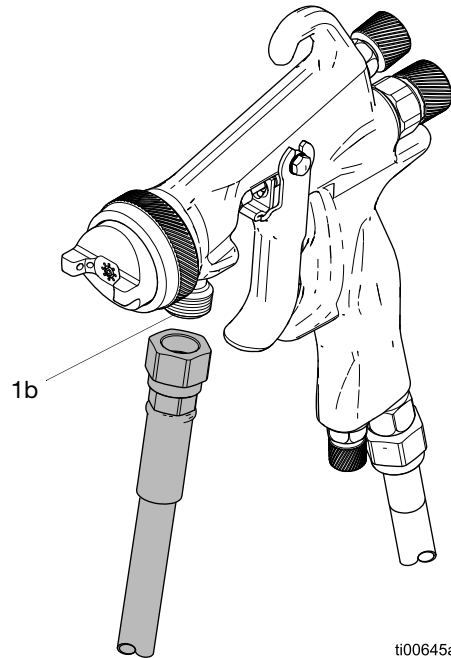

ti00645a

FIG. 4: Connect the gun fluid supply hose

4. Connect the other end of the gun fluid supply hose to the pump fluid outlet.

Position the Air Cap

Vertical Spray Pattern

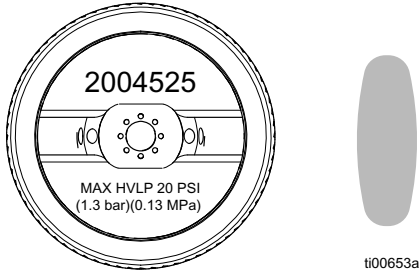

FIG. 5: Vertical Spray Pattern Position

Horizontal Spray Pattern

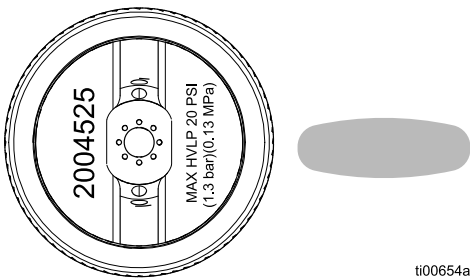

FIG. 6: Horizontal Spray Pattern Position

Adjust Spray Pattern

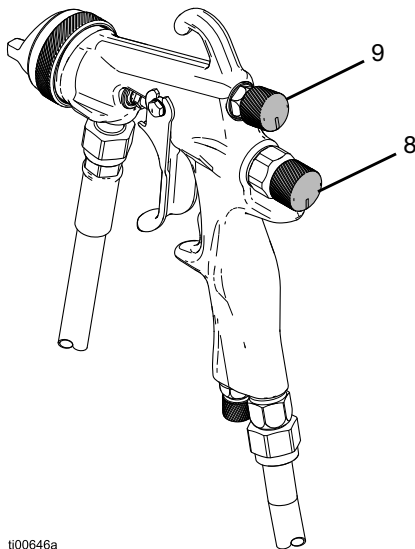

FIG. 7

Set Fluid Flow

1. Set the Fluid Pressure Regulator. Typical industrial flow rates will vary with regulator pressures from 5–30 psi (34–210 kPa, 0.3–2.1 bar).
2. Set the fluid control valve (8):
 - a. Open the valve. Turn the fluid control valve (8) counterclockwise until the trigger movement is not restricted.
 - b. Then turn another half turn.

NOTICE

Use caution when operating the fluid control valve (8) near the closed position. The needle tip may be damaged if forced too hard against the nozzle seat by the fluid control valve.

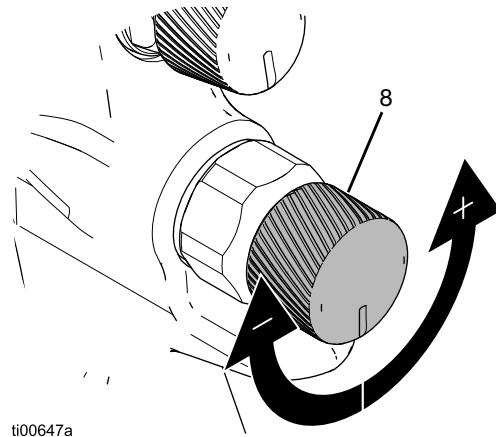

FIG. 8: Fluid Control Valve Adjustments

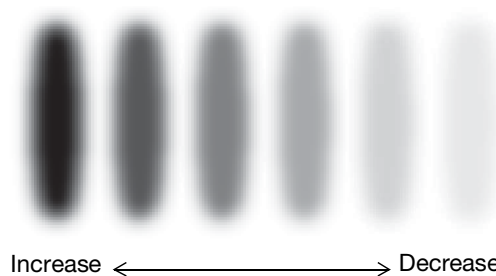
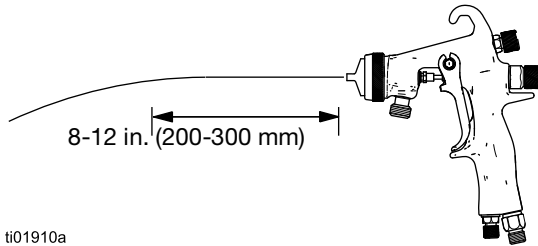

FIG. 9: Fluid Flow Coverage

3. Adjust the fluid flow with the air pressure regulator until the stream from the gun travels 8-12 in. (200-300 mm) before falling off. Typically, if fluid pressure is below 5 psi (.04 MPa, 0.4 bar) or above 20 psi (0.14 MPa, 1.4 bar), a change of nozzle size is recommended.



ti01910a

- **Adjust nozzle size:** Check fluid pressure and change nozzle if needed.
 - If the fluid pressure is too high at the desired flow rate, install a larger nozzle.
 - If the fluid pressure is too low at the desired flow rate, install a smaller nozzle.

NOTE: A larger fluid nozzle at a reduced fluid pressure will maintain the same flow rate, but the fluid stream (velocity) will slow down. When air is applied, the lower velocity allows the air to act on the fluid longer, which improves atomization.

Supply Air

Use the air pressure regulator to set the fan and atomizing air supply pressure. Use the **Recommended Starting Pressures** as a starting point.

Recommended Starting Pressures

Application and Technology	Supply Air psi (MPa, bar)
General Industry: Conventional	35 (0.24, 2.4)
General Industry: HVLP	25 (0.17, 1.7)
General Industry: Compliant	25 (0.17, 1.7)
Trim: HVLP	10 (0.07, 0.7)
Adhesive	20 (0.14, 1.4)
Automotive: Conventional	35 (0.24, 2.4)
Automotive: Compliant	25 (0.17, 1.7)
Automotive: HVLP	20 (0.14, 1.4)
High Solids: Conventional	35 (0.24, 2.4)
High Solids: Compliant	25 (0.17, 1.7)
High Solids: HVLP	20 (0.14, 1.4)
Waterborne	35 (0.24, 2.4)
Wood: Conventional	25 (0.17, 1.7)
Wood: Compliant	20 (0.14, 1.4)
Wide Pattern: Conventional	25 (0.17, 1.7)
Wide Pattern: Compliant	25 (0.17, 1.7)
Wide Pattern: HVLP	20 (0.14, 1.4)

Set Spray Pattern

1. Adjust the fan control valve (9) to the fully open position.
2. Adjust the fluid control valve (8) to the fully open position.
3. Set the air pressure using the values found in the **Recommended Starting Pressures** table.
4. Test the spray pattern while keeping the gun at a consistent distance, about 6-8 in. (150-200 mm), from the test piece.
5. Adjust the fluid flow rate, input air pressure, and fan control valve (9) to achieve the desired atomization, fluid flow rate, and pattern size.

NOTE: For the best transfer efficiency, use the lowest setting needed to achieve desired finish quality.

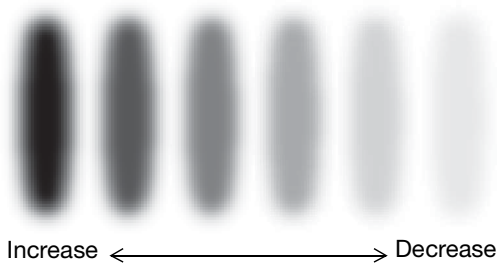

ti00113a

FIG. 10: Atomizing Air

Test Fan and Atomizing Air

Test the spray pattern while keeping the gun a consistent distance, about 6–8 in. (150–200 mm), from the test piece. Adjust atomizing and fan air as needed.

Adjust Atomizing Air

For the best transfer efficiency, use the lowest setting needed to achieve desired finish quality.

Increase the gun inlet pressure with the air pressure regulator in 5 psi (34 kPa, 0.3 bar) increments until you obtain the desired atomization.

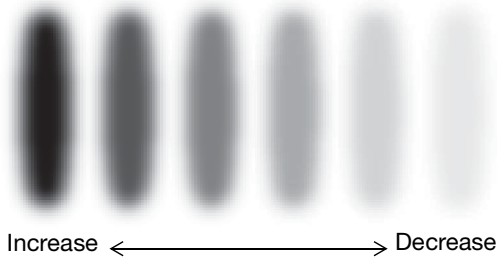

ti00113a

FIG. 11: Atomizing Air

Adjust Fan Air and Pattern Width

If the spray pattern is too wide or split, reduce the fan air pressure by adjusting the fan control valve (9).

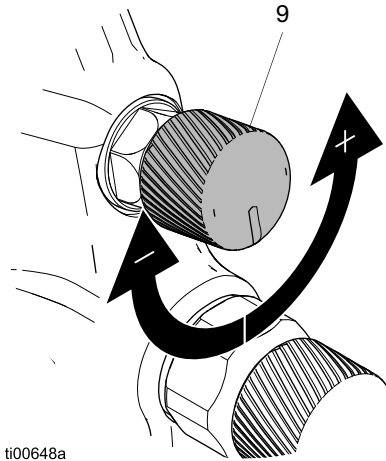

ti00648a

FIG. 12: Fan Air

To further control the spray pattern, use an alternate air cap.

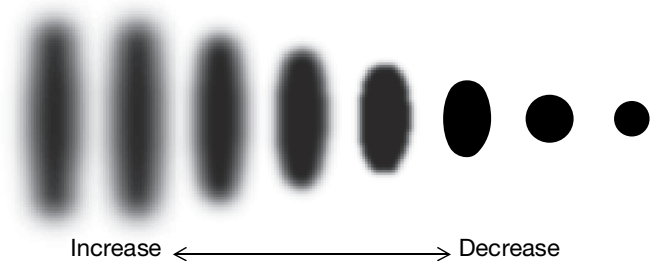



FIG. 13: Fan Air

HVLP Gun Limits

In some areas, an HVLP gun is required for compliance with environmental standards. To comply with HVLP requirements, the air pressure at the air cap must be less than 10 psi (0.07 MPa, 0.7 bar).

Operation

Pressure Relief Procedure

 Follow the Pressure Relief Procedure whenever you see this symbol.



This equipment stays pressurized until pressure is manually relieved. To help prevent serious injury from pressurized fluid, such as splashing fluid, follow the Pressure Relief Procedure when you stop spraying and before cleaning, checking, or servicing the equipment.

1. Turn off the fluid and air supply to the gun.
2. Hold a metal part of the gun firmly to a grounded metal pail. Trigger the gun to relieve pressure.

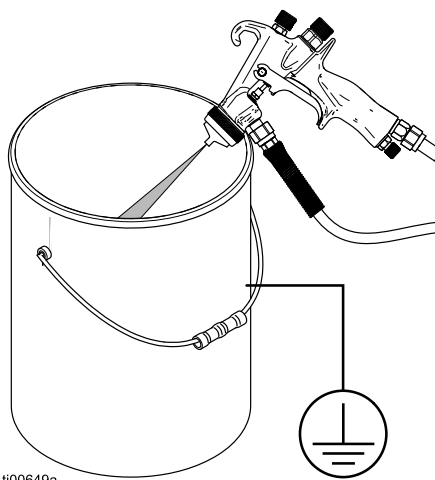

ti00649a

FIG. 14: Relieve gun pressure

Optional: Open all fluid drain valves in the system with a waste container ready to catch drainage.

3. If you suspect the nozzle or gun fluid supply hose is clogged or that pressure has not been fully relieved:
 - a. VERY SLOWLY loosen the retaining ring or the hose end coupling to relieve pressure gradually.
 - b. Loosen the nut or the coupling completely.
 - c. Clear the obstruction in the hose or nozzle.

Spray Finishing Application

1. Maintain a distance of approximately 8 to 12 in. (200 to 300 mm) from the object being sprayed.
2. Hold the gun perpendicular to the surface.
3. Engage the trigger.
4. Spray smooth, even, and parallel strokes. Overlap each stroke by 50% for even coverage. **Do not arc the strokes.** Arcing causes uneven coverage. See FIG. 15.

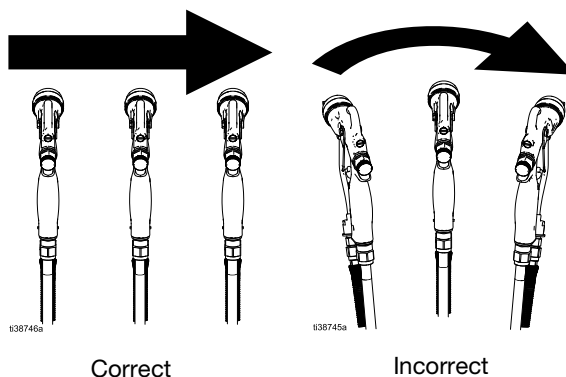

FIG. 15: Spray techniques

NOTE: This spray gun applies all coatings evenly without cross coating.

Maintenance

<p>To reduce the risk of an injury from splashing fluid, follow the Pressure Relief Procedure, page 13, whenever you are instructed to relieve the pressure.</p>				

- Follow the **Daily Cleaning Procedure** every day.
- Flush before changing colors, before fluid can dry in the equipment, at the end of the day and before storing.
- Flush at the lowest pressure possible. Check connections for leaks and tighten as necessary.
- Flush with a fluid that is compatible with the fluid being dispensed and the equipment wetted parts.

NOTICE
<p>Methylene chloride with formic or propionic acid is not recommended as a flushing or cleaning solvent with this gun as it will damage aluminum and nylon components.</p>

- Clean the front of the air cap regularly to reduce buildup.
- Do not use any cleaning method which may allow solvent into the gun air passages. Solvent left in gun air passages could result in a poor quality paint finish.
 - Do not point gun up while cleaning.
 - Do not wipe the gun with a cloth soaked in solvent; wring out the excess.
 - Do not immerse the gun in solvent.

Flushing Procedure

<p>To avoid fire and explosion, always ground equipment and waste container. To avoid static sparking and injury from splashing fluid, always flush at the lowest possible pressure.</p>				

1. Follow the **Pressure Relief Procedure**, page 13.
2. Connect a solvent supply hose to the gun.
3. To maintain grounding continuity hold metal part of the spray gun firmly to the side of a grounded metal solvent pail.
4. Starting with the lowest possible fluid pressure, trigger the gun into a grounded metal solvent pail.
5. Increase the fluid pressure slowly. Flush until clean solvent flows from the gun.

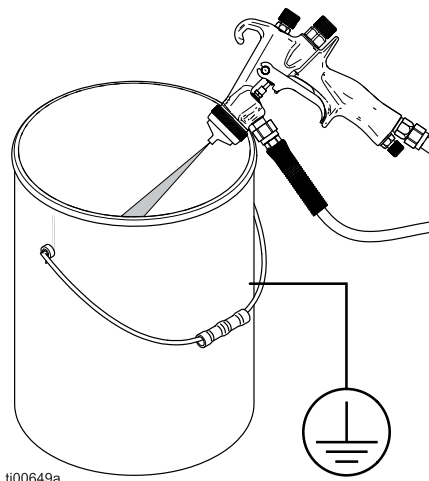
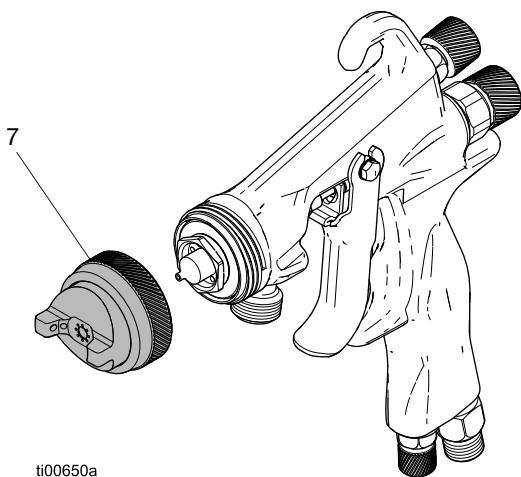

FIG. 16: Relieve gun pressure

6. De-trigger the gun.
7. Turn off the solvent supply.
8. Follow the **Pressure Relief Procedure**, page 13.

Daily Cleaning Procedure

1. Follow the **Pressure Relief Procedure**, page 13.
2. Flush the equipment. See **Flushing Procedure**, page 14.
3. Remove the air cap assembly (7).



ti00650a

FIG. 17: Remove Air Cap Assembly

4. Dip the end of a soft-bristle brush into a compatible solvent. Do not continuously soak the brush's bristles.

NOTICE

Do not use metal tools to clean the air cap assembly parts. Metal tools may scratch the air cap and cause spray pattern distortion.

5. Clean the components. Replace seals as needed.
 - a. Clean the parts with a soft-bristle brush.
 - b. Use a soft tool, such as an unblocking needle or tooth pick, to clean the air inlet holes.

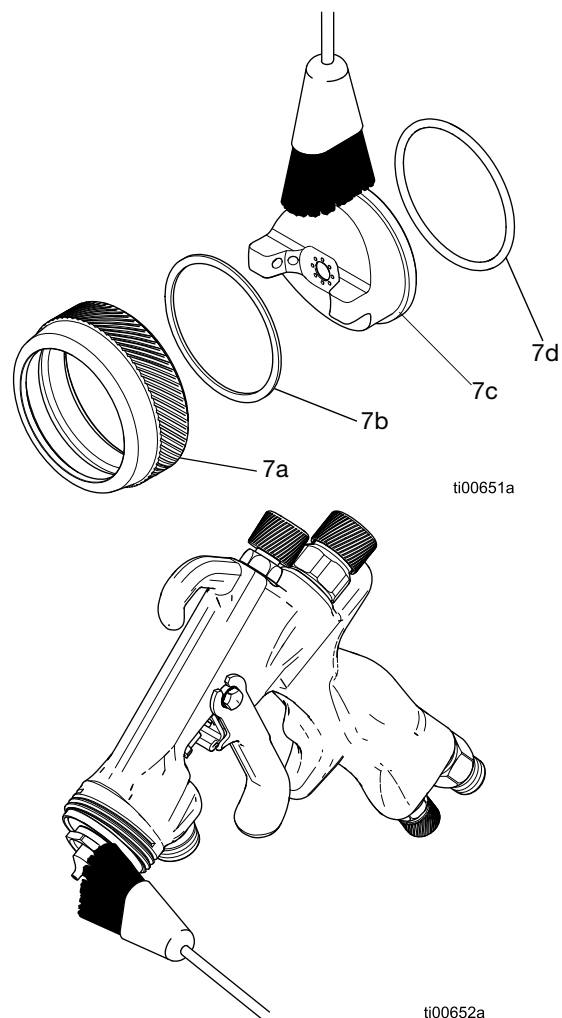

ti00651a

ti00652a

FIG. 18: Clean Air Cap Components

6. Dampen a soft cloth with solvent and wring-out the excess. Point the gun down and wipe off the outside of the gun.
7. Assemble and install the air cap assembly (7). See **Position the Air Cap**, page 10.

Recycling and Disposal

End of Product Life

At the end of the product's useful life, dismantle and recycle it in a responsible manner.

- Perform the **Pressure Relief Procedure**.
- Drain and dispose of fluids according to applicable regulations. Refer to the material manufacturer's Safety Data Sheet.
- Deliver remaining product to a recycling facility.

Troubleshooting



Follow **Pressure Relief Procedure**, page 13, before checking or repairing the equipment.

NOTE: Check all possible problems and causes before disassembling the equipment.

Spray Pattern Troubleshooting

Spray Pattern	Cause	Solution
<p>Correct</p>	Normal pattern.	No action necessary.
<p>Heavy Top or Bottom</p>	Dirty or damaged air cap or fluid nozzle.	<p>Rotate air cap (7c) 180°.</p> <p><i>If pattern follows air cap, problem is in air cap. Clean and inspect. If pattern is not corrected, replace air cap.</i></p> <p><i>If pattern does not follow the air cap, the problem is with the fluid cartridge (3). Clean and inspect the cartridge. If the pattern is not corrected, replace fluid cartridge.</i></p>
<p>Heavy Top and Bottom, Split Pattern</p>	Pressure too high for viscosity of material being sprayed.	<p>Reduce air pressure and increase material viscosity.</p> <p>Correct pattern by narrowing fan size with the fluid control valve (8).</p>
	Air pressure controlling the fan pattern is too high.	<p>Narrow the fluid pattern by adjusting the fan control valve (9).</p> <p>Reduction of air pressure to the gun may also be required.</p>
<p>Spray Pattern</p>	Dirty or distorted air horn holes.	Clean and inspect air cap (7c). If pattern is not corrected, replace air cap.

General Troubleshooting

Problem	Cause	Solution
Gun spitting.	Air getting into paint stream.	Check if fluid source is empty and fill. Tighten fluid cartridge (3). Check and tighten needle packing nut (3f). Check fluid cartridge (3) for damage.
Will not spray.	Fluid control valve (8) turned too far clockwise.	Adjust fluid control valve (8) counterclockwise.
	Fluid source empty.	Refill.
Excessive air blowing back.	Loose fluid cartridge (3).	Tighten fluid cartridge (3).
	Damaged fluid nozzle seal (3d, 3e).	Replace seal (3d, 3e).
Excessive air leak behind trigger.	Worn u-cups/air valve.	Repair gun (Kit 2006029). Be sure to use all included parts.
	Worn trigger (11).	Replace trigger (11). If leak persists repair gun (Kit 2006029).
Gun fluid pressure is too high with gun triggered (cannot achieve desired flow rate).	Using needle/nozzle kit with too small orifice.	Use needle/nozzle kit with larger orifice.
Using a low fluid pressure setting, the fluid flow is too high, making it necessary to restrict needle travel to reduce fluid flow.	Using needle/nozzle kit with too large orifice.	Use needle/nozzle kit with smaller orifice.
Fluid system will not operate at low enough pressure [below 10 psi (70 kPa, 0.7 bar)].	There is no fluid regulator, or air regulator is not sensitive enough at low pressure.	Add low pressure fluid regulator, or add more sensitive low pressure air regulator.
Fluid flow is fluttering while spraying.	Fluid filter clogged.	Check fluid filter.
	Fluid source empty.	Refill.
	Air pressure is too high.	Decrease the air pressure, or lower the fluid pressure.
Fluid flow fades while spraying high viscosity fluids.	Air pressure is too high.	Decrease the air pressure, or lower the fluid pressure.

Repair



Prepare Equipment for Service

1. Follow the **Pressure Relief Procedure**, page 13.
2. Follow the **Flushing Procedure**, page 14.
3. Turn off system air.

Fluid Cartridge Repair

Remove the Fluid Cartridge

1. **Prepare Equipment for Service.** See page 19.
2. Push the trigger quick release (13) on the side of the gun and remove the trigger (11).

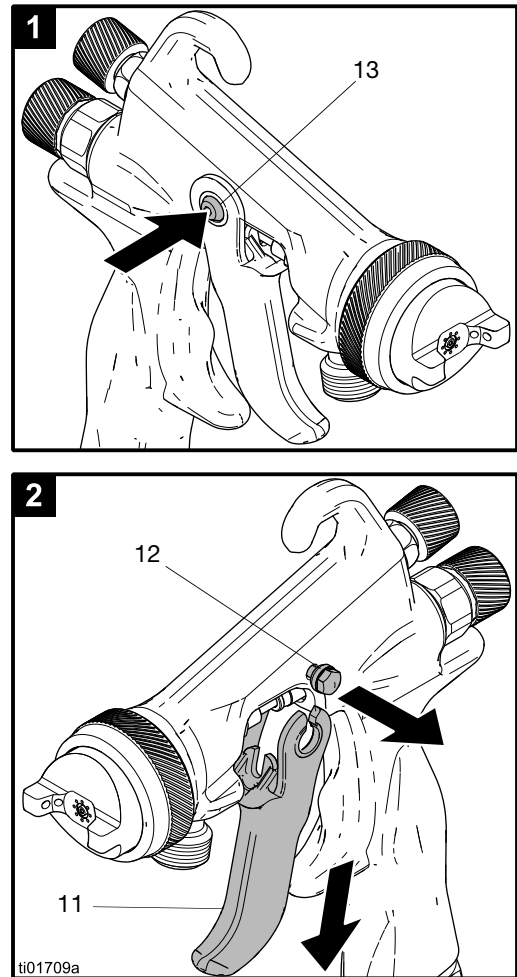

FIG. 19: Remove Trigger

3. Loosen the air cap retaining ring (7a) to remove the air cap assembly (7).
4. Use a wrench or a gun tool to remove the fluid cartridge (3). See FIG. 20.
5. Remove the baffle (2), if needed. See FIG. 20.

Install the Fluid Cartridge

Lubricate components with the recommended **Light-Weight Lubricant** on page 30.

1. Ensure the baffle (2) is in place. The flat side of the baffle faces away from the gun body.
2. Lubricate the seals (3d and 3e).
3. Use a wrench or gun tool to tighten the assembled fluid cartridge (3) into the gun body. Torque to 155–165 in-lb (17.5–18.6 N•m).

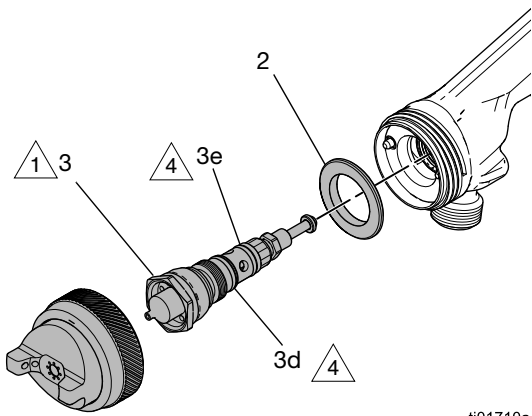

1 Torque to 155–165 in-lb (17.5–18.6 N•m)

4 Lubricate with recommended **Light-Weight Lubricant**

FIG. 20: Fluid Cartridge Assembly

Disassemble the Fluid Cartridge

1. Remove the fluid cartridge (3) from the gun. See FIG. 20.
2. Separate the fluid needle (3j) from the fluid cartridge (3).

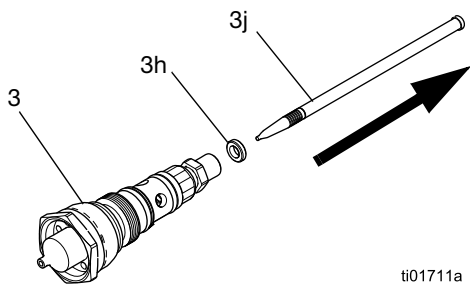

FIG. 21: Fluid Cartridge and Fluid Needle

3. Replace the needle tip as needed. Apply medium-strength threadlocker to the needle threads before installing the tip replacement.

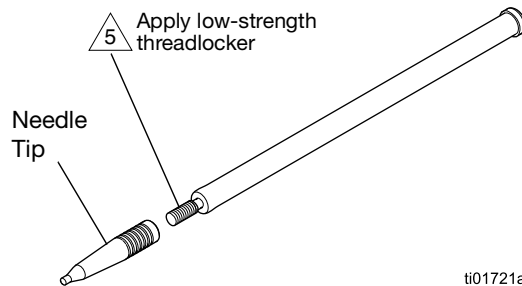

FIG. 22: Needle Assembly

4. Decouple the fluid nozzle (3a) and fluid insert (3b).

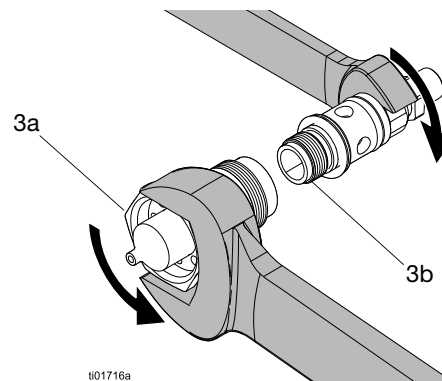

FIG. 23: Nozzle and Fluid Insert

5. Decouple the packing nut (3c) and the fluid insert (3b).
6. Remove the u-cup spreader (3g) and u-cup packing (3f) from the packing nut (3c).
7. Use a pick to remove the fluid insert o-ring seals (3d and 3e).

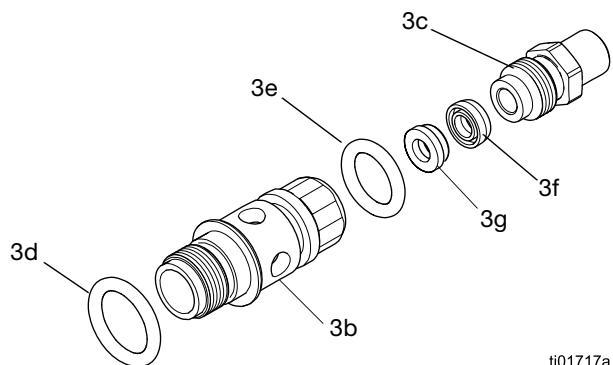
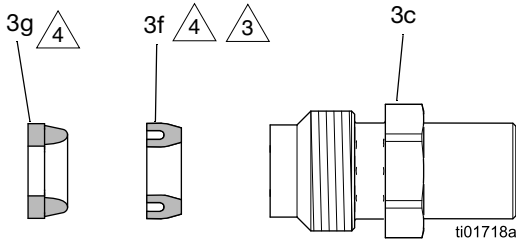

FIG. 24: Fluid Insert and Packing Nut

Assemble the Fluid Cartridge

Replace parts as needed and assemble the fluid cartridge. Lubricate components with the recommended **Light-Weight Lubricant** on page 30.

1. Replace the fluid insert o-ring seals (3d and 3e).
2. Assemble the u-cup spreader (3g) and u-cup packing (3f) into the packing nut (3c). Note the u-cup spreader (3g) and u-cup packing (3f) orientation in FIG. 25. Apply lubricant to the center of the assembled packing nut.
3. Install the assembled packing nut (3c) into the fluid insert. Torque the packing nut (3c) to 3 in-lb (0.3 N•m).



- 4 Lubricate with recommended **Light-Weight Lubricant**.
- 3 The step on the packing seal faces into the packing nut

FIG. 25: Spacer Orientation

4. Install the nozzle (3a) onto the fluid insert (3b). Torque to 120 in-lb (13.6 N•m). See FIG. 23.
5. Install the needle (3j) into the fluid cartridge. See FIG. 21.
6. Lubricate the seals (3d and 3e).
7. Install the fluid cartridge (3) into the gun body. Torque to 155-165 in-lb (18-19 N•m). See FIG. 20.
8. Push the trigger quick release (13) on the side of the gun and reinstall the trigger (11). Make sure the washer on the needle (3h) is behind the trigger when reinstalling. See FIG. 26.

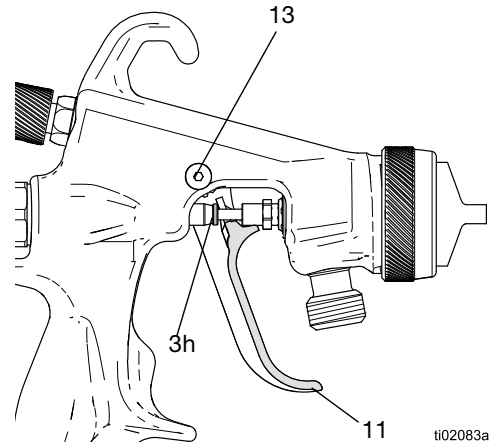

FIG. 26: Replace Trigger

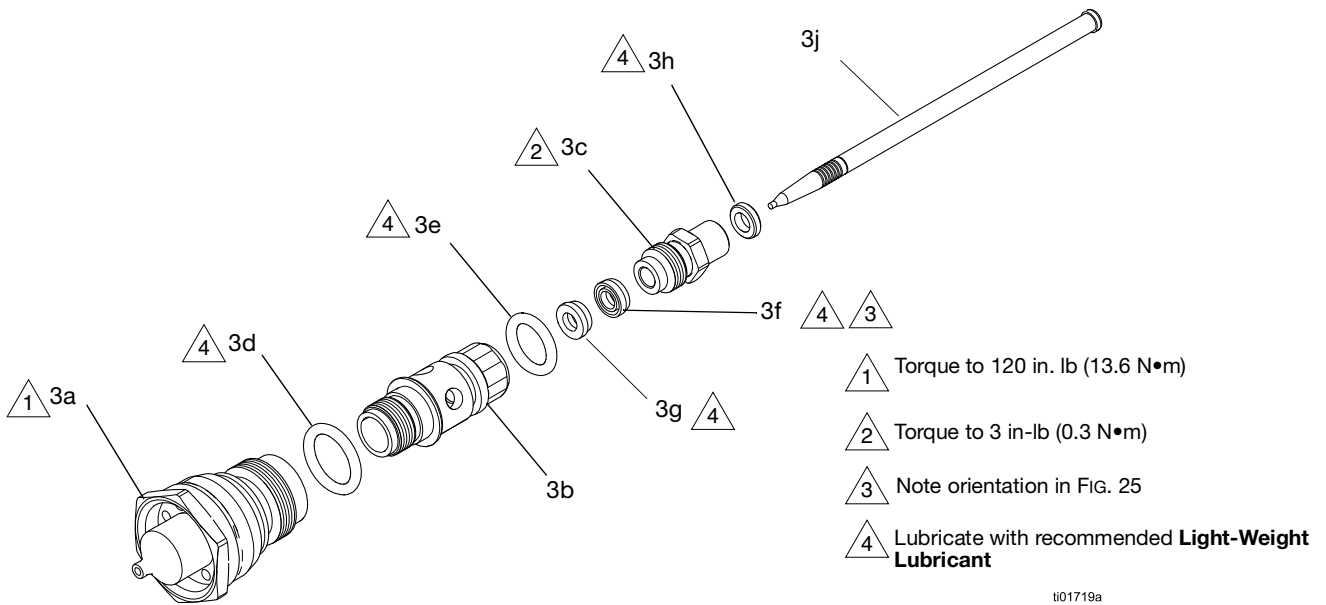

FIG. 27: Fluid Cartridge Assembly

Fluid Control Valve Repair

Remove the Fluid Control Valve

1. **Prepare Equipment for Service.** See page 19.
2. **Remove the Fluid Cartridge.** See page 19.
3. Use a wrench or a gun tool to remove the fluid adjustment housing (8).
4. Remove the spring (22), air valve stem (21), fluid adjustment valve (20), and the packing u-cup (5).

Install the Fluid Control Valve

Lubricate components with the recommended **Light-Weight Lubricant** on page 30.

1. Insert the packing u-cup (5), fluid adjustment valve (20), air valve stem (21), and spring (22) into the back of the gun.
2. Use a wrench or gun tool to tighten the fluid adjustment housing (8) into the gun body. Torque to 205–215 in-lb (23.2-24.3 N•m).

NOTE: Make sure the air valve stem (21) is oriented as shown in FIG. 28. The spring (22) should rest on the flat side of the air valve stem (21) when installed into the back of the gun.

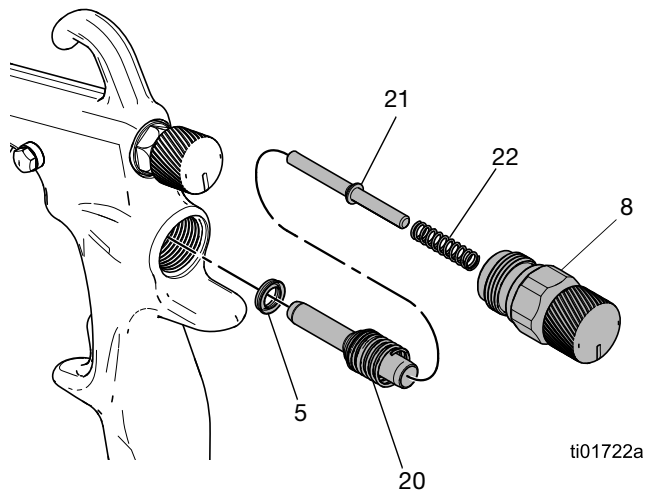

FIG. 28: Fluid Control Valve Assembly

Fan Control Valve Repair

Remove the Fan Control Valve

1. **Prepare Equipment for Service.** See page 19.
2. Use a wrench or a gun tool to remove the fan control Valve assembly (9).

Install the Fan Control Valve

Install the fan control valve assembly (9) into the gun body, with the valve turned fully counterclockwise to the outermost position. Torque to 85–90 in-lb (9.6-10.2 N•m).

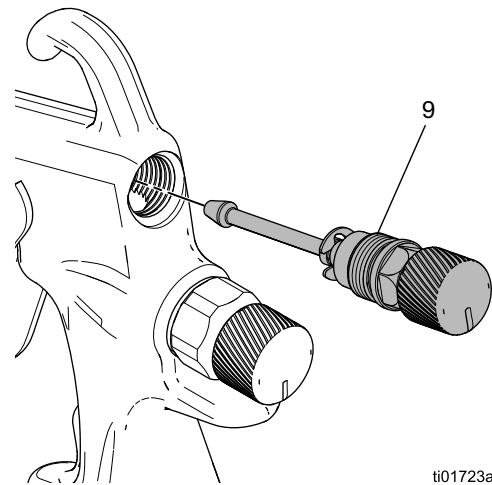

FIG. 29: Fan Control Valve Assembly

Air Inlet Valve Repair

Remove the Air Inlet Valve

1. **Prepare Equipment for Service.** See page 19.
2. Use a wrench or a gun tool to remove the air inlet valve assembly (10).

Install the Air Inlet Valve

Install the air inlet valve assembly (10) into the gun body, with the valve turned fully counterclockwise to the outermost position. Torque to 85–90 in-lb (9.6-10.2 N•m).

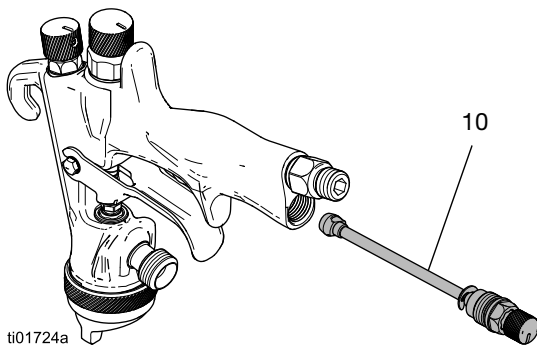
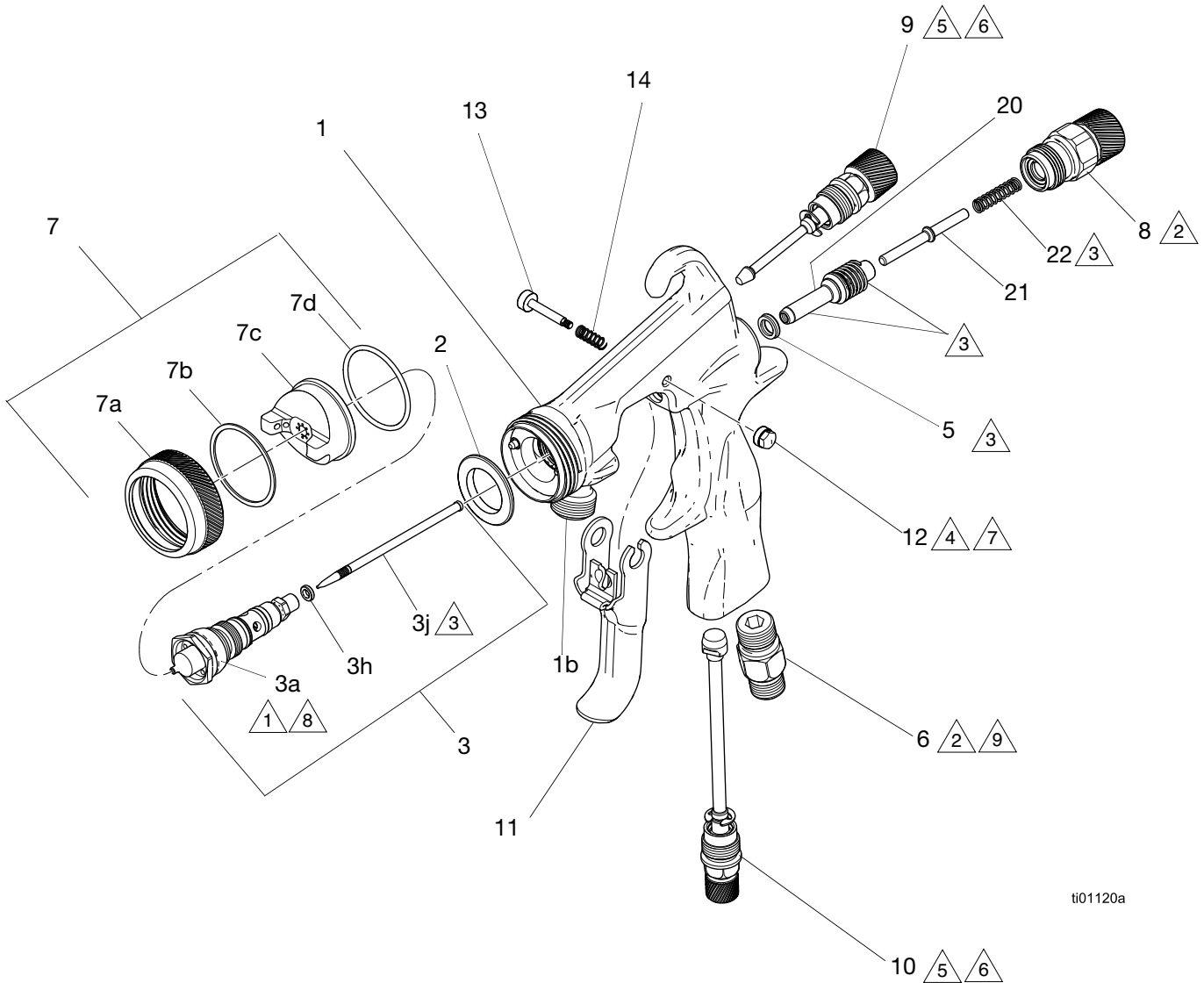

FIG. 30: Air Inlet Valve Assembly

Parts



ti01120a

- △1 Remove trigger before installing nozzle (3).
- △2 Torque to 205-215 in-lbs (23.2-24.3 N•m).
- △3 Apply lubricant.
- △4 Apply low strength thread retainer.
- △5 Install with valve assembly turned fully counterclockwise to outermost position.
- △6 Torque to 85-90 in-lbs (9.6-10.2 N•m).
- △7 Torque to 15-20 in-lbs (1.7-2.2 N•m).
- △8 Torque to 155-165 in-lbs (17.5-18.6 N•m).
- △9 Torque to 235 in-lbs (26.6 N•m).

Ref.	Part	Description
1	---	BODY, gun
☼*1a	---	GASKET, fluid inlet
☼1b	---	FITTING, fluid inlet
2	2008110	BAFFLE, air, kit, 5 pieces
3	See Fluid Cartridge Kits , page 26	CARTRIDGE, fluid (includes 3a-3j)
3a		NOZZLE, fluid
3b		INSERT, fluid
†❖3c		NUT
†❖3d		O-RING
†❖3e		O-RING
✓†❖3f		PACKING, u-cup
✓†❖3g		SPREADER, u-cup
❖3h		WASHER, needle
3j		NEEDLE, fluid
5✓☼		---
6	289451	FITTING, air inlet
7	---	AIR CAP, assembly (includes 7a-7d)
+7a	---	RING, retaining
+◆✓×7b	---	WASHER
×7c	---	AIR CAP
+◆✓×7d	---	O-RING
8☼	2004207	HOUSING, fluid adjustment assembly (includes 8a)
8a	---	PACKING, u-cup
9	2004186	VALVE, fan control
10	2004208	VALVE, air inlet
11★	2004187	TRIGGER, quick release
12★	---	NUT, trigger
13★	---	PIN, trigger
14★	---	SPRING, trigger
18*	2004209	NUT, air plug
20✓☼	2004206	VALVE, air assembly
21☼	---	STEM, air valve
22☼	---	SPRING, fluid
23*✓	---	TOOL, seal installation

✓ Included in **Gun Repair Kit**, page 26.

◆ Included in **Air Cap Seal Kit**, page 26.

☼ Included in **Air Section Repair Kit**, page 26.

★ Included in **Trigger Repair Kit**, page 26.

+ Included in **Retaining Ring Kit**, page 26.

☼ Included in **Fluid Inlet Fitting Kit**, page 26.

❖ Included in **Fluid Cartridge Repair Kit**, page 26.

† Included in **High Wear Fluid Cartridge Repair Kit**, page 26.

× Included in **Air Cap Kits**, page 27.

* Not Shown

Kits and Accessories

Repair Kits

See **Parts**, page 24.

Part	Description
2006038✓	Gun Repair Kit
289791◆	Air Cap Seal Kit
2006029✿	Air Section Repair Kit
2004188★	Trigger Repair Kit
2006029	Air Valve Repair Kit
2004189+	Retaining Ring Kit
24C269✱	Fluid Inlet Fitting Kit
26A102	Fluid Inlet Fitting with Flats Kit
2006040	Gun Assembly Kit
2006033❖	Fluid Cartridge Repair Kit
2007155†	High Wear Fluid Cartridge Repair Kit

✓ Includes one each of 3f, 3g, 7b, 7d, 20, and 23, and contains three of 5.

◆ Includes five of 7b and 7d.

✿ Includes one each of 5, 8, 20, 21, and 22.

★ Includes five each of 11, 12, 13, and 14.

✚ Includes one each of 7a, 7b, and 7d.

✱ Includes one each of 1a and 1b.

❖ Includes five each of 3c-3h.

† Includes five each of 3c-3g.

Needle Assembly Kits

NOTE: Kits include needle washer (3h).

Kit Number	Needle Assembly with Washer Size in. (mm)
2006021	0.02 (0.5)
2006022	0.03 (0.8)
2006023	0.040–0.042 (1.0–1.1)
2006024	0.051, 0.055, 0.070 (1.3, 1.4, 1.8)
2006025	0.086 (2.2)
2006026	0.11 (2.8)
2006027	0.042 (1.1) SST
2006028	0.055–0.070 (1.4–1.8) SST
2006030	0.059 (1.5) High Wear
2006031	0.070 (1.8) High Wear
2006032	0.086 (2.2) High Wear

Fluid Cartridge Kits

Kit	Nozzle Only Kit	Fluid Cartridge Nozzle Size in. (mm)
2004190	25F233	0.02 (0.5)
2004191	25F224	0.03 (0.8)
2004192	25F222	0.040 (1.0)
2004193	25F225	0.042 (1.1)
2004194	25F226	0.055 (1.4)
2004195	25F227	0.070 (1.8)
2004196	25F228	0.086 (2.2)
2004197	25F229	0.11 (2.8)
2004198	25F222	0.042 (1.1) SST tip
2004199	25F233	0.055 (1.4) SST tip
2004200	25F234	0.070 (1.8) SST tip
2004201	25F233	0.051 (1.3) Adhesives
2004202	25F234	0.070 (1.8) Adhesives
2004203	---	0.059 (1.5) High Wear
2004204	---	0.070 (1.8) High Wear
2004205	---	0.086 (2.2) High Wear

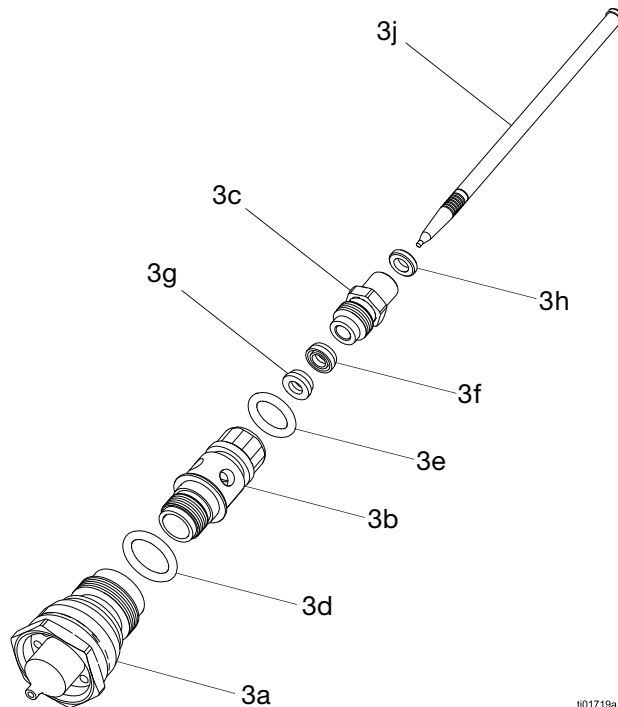

FIG. 31: Fluid Cartridge

Air Cap Kits

Part	Air Cap	Spray Type	Air Cap Color
2004525	General Industry	HVLP	Black
2004526	General Industry	Compliant	Nickel
2004527	General Industry and Auto- motive	Conventional	Blue Gray
	General Industry		
	Automotive		
2004528	General Industry	Conventional	Blue Gray
2004530	Trim	HVLP	Green
2004532	Wide Pattern	HVLP	Silver
2004533	General Industry	Conventional	Blue Gray
2004534	General Industry	Conventional	Blue Gray
288861	High Solids	Conventional	Blue Gray
288862	Wood	Conventional	Blue Gray
288864	Wood	HVLP	Pewter
289043	General Industry	HVLP	Pewter
289044	General Industry	Compliant	Nickel
289045	General Industry	Compliant	Nickel
289046	Waterborne	Conventional	Blue Gray
289047	Waterborne	HVLP	Pewter
289049	High Solids	Conventional	Blue Gray
289050	High Solids	Compliant	Nickel
289051	Adhesives	Conventional	Blue Gray
289070	General Industry	HVLP	Pewter
289325	High Solids	HVLP	Pewter
289327	High Solids	Compliant	Nickel
289771	Automotive	HVLP	Pewter
289772	Automotive	Compliant	Nickel

Spray Component Kits

Air Cap	Spray Type	Nozzle Size in. (mm)	Tip Construction	Model	Air Cap Kit w/o O-Rings	Fluid Cartridge w/ Needle	Needle Assembly w/ washer	Needle Tip (5 pack)
General Industry	Conventional	0.020 (0.5)	PEEK Tip	N/A	2004527	2004190	2006021	289350
General Industry and Automotive		0.030 (0.8)	PEEK Tip	2004146	2004527	2004191	2006022	288183
General Industry and Automotive		0.042 (1.1)	PEEK Tip	2004147	2004527	2004193	2006023	288184
General Industry and Automotive		0.055 (1.4)	PEEK Tip	2004145	2004527	2004194	2006024	288185
General Industry		0.070 (1.8)	PEEK Tip	2004148	2004528	2004195	2006024	288185
General Industry		0.086 (2.2)	PEEK Tip	2004149	2004533	2004196	2006025	289004
General Industry		0.110 (2.8)	PEEK Tip	2004150	2004534	2004197	2006026	289007
General Industry	HVLP	0.020 (0.5)	PEEK Tip	N/A	2004525	2004190	2006021	289350
General Industry		0.030 (0.8)	PEEK Tip	2006145	2004525	2004191	2006022	288183
General Industry		0.042 (1.1)	PEEK Tip	2004151	2004525	2004193	2006023	288184
General Industry		0.055 (1.4)	PEEK Tip	2004152	2004525	2004194	2006024	288185
General Industry		0.070 (1.8)	PEEK Tip	2004153	2004525	2004195	2006024	288185
General Industry		0.086 (2.2)	PEEK Tip	2006146	289070	2004196	2006025	289004
General Industry		0.110 (2.8)	PEEK Tip	2006147	289043	2004197	2006026	289007
General Industry	Compliant	0.020 (0.5)	PEEK Tip	N/A	2004526	2004190	2006021	289350
General Industry		0.030 (0.8)	PEEK Tip	N/A	2004526	2004191	2006022	288183
General Industry		0.042 (1.1)	PEEK Tip	2004154	2004526	2004193	2006023	288184
General Industry		0.055 (1.4)	PEEK Tip	2004155	2004526	2004194	2006024	288185
General Industry		0.070 (1.8)	PEEK Tip	2004156	2004526	2004195	2006024	288185
General Industry		0.086 (2.2)	PEEK Tip	2006148	289044	2004196	2006025	289004
General Industry		0.110 (2.8)	PEEK Tip	2006149	289045	2004197	2006026	289007
General Industry	Conventional	0.042 (1.1)	SST Tip	N/A	2004527	2004198	2006027	289010
General Industry	Conventional	0.055 (1.4)	SST Tip	2004157	2004527	2004199	2006028	289013
General Industry	Conventional	0.070 (1.8)	SST Tip	2004158	2004528	2004200	2006028	289013
General Industry and Automotive	Conventional	0.042 (1.1)	SST Tip	2004163	289040	2004198	2006027	289010
General Industry and Automotive	Conventional	0.055 (1.4)	SST Tip	2004164	289040	2004199	2006028	289013
General Industry	HVLP	0.042 (1.1)	SST Tip	N/A	2004525	2004198	2006027	289010
General Industry	HVLP	0.055 (1.4)	SST Tip	2004159	2004525	2004199	2006028	289013
General Industry	HVLP	0.070 (1.8)	SST Tip	2004160	2004525	2004200	2006028	289013
General Industry	Compliant	0.042 (1.1)	SST Tip	N/A	2004526	2004198	2006027	289010
General Industry	Compliant	0.055 (1.4)	SST Tip	2004161	2004526	2004199	2006028	289013
General Industry	Compliant	0.070 (1.8)	SST Tip	2004162	2004526	2004200	2006028	289013
Automotive	Conventional	0.030 (0.8)	PEEK Tip	2004146	2004527	2004191	2006022	288183
Automotive	Conventional	0.042 (1.1)	PEEK Tip	2004147	2004527	2004193	2006023	288184
Automotive	Conventional	0.055 (1.4)	PEEK Tip	2004145	2004527	2004194	2006024	288185
Automotive	HVLP	0.055 (1.4)	PEEK Tip	2004165	289771	2004194	2006024	289001
Automotive	Compliant	0.055 (1.4)	PEEK Tip	2004166	289772	2004194	2006024	288185

Air Cap	Spray Type	Nozzle Size in. (mm)	Tip Construction	Model	Air Cap Kit w/o O-Rings	Fluid Cartridge w/ Needle	Needle Assembly w/ washer	Needle Tip (5 pack)
Wood	Conventional	0.040 (1.0)	PEEK Tip	2004178	288862	2004192	2006023	288184
Wood	HVLP	0.040 (1.0)	PEEK Tip	2004179	288864	2004192	2006023	288184
Wood (no fluid adjust)	HVLP	0.040 (1.0)	PEEK Tip	2006150	288864	2004192	2006023	288184
Adhesives	Conventional	0.051 (1.3)	PEEK Tip	2004173	289051	2004201	2006024	288185
Adhesives	Conventional	0.070 (1.8)	PEEK Tip	2004174	289051	2004202	2006024	288185
Waterborne	Conventional	0.042 (1.1)	PEEK Tip	2006151	289046	2004193	2006023	288184
Waterborne	Conventional	0.055 (1.4)	PEEK Tip	2004177	289046	2004194	2006024	288185
Waterborne	HVLP	0.042 (1.1)	PEEK Tip	N/A	289047	2004193	2006023	288184
Waterborne	HVLP	0.055 (1.4)	PEEK Tip	N/A	289047	2004194	2006024	288185
High Solids*	Conventional	0.059 (1.5)	High Wear	2006152	288861	2004203	2006030	N/A
High Solids*	Conventional	0.070 (1.8)	High Wear	2004167	289049	2004204	2006031	N/A
High Solids*	Conventional	0.086 (2.2)	High Wear	2004168	289049	2004205	2006032	N/A
High Solids*	HVLP	0.059 (1.5)	High Wear	N/A	289115	2004203	2006030	N/A
High Solids*	HVLP	0.070 (1.8)	High Wear	2004169	289325	2004204	2006031	N/A
High Solids*	HVLP	0.086 (2.2)	High Wear	2004170	289325	2004205	2006032	N/A
High Solids*	Compliant	0.059 (1.5)	High Wear	2006153	289050	2004203	2006030	N/A
High Solids*	Compliant	0.070 (1.8)	High Wear	2004171	289327	2004204	2006031	N/A
High Solids*	Compliant	0.086 (2.2)	High Wear	2004172	289327	2004205	2006032	N/A
Trim	HVLP	0.042 (1.1)	PEEK Tip	N/A	2004530	2004193	2006023	288184
Trim	HVLP	0.055 (1.4)	PEEK Tip	N/A	2004530	2004194	2006024	288185
Wide Pattern	HVLP	0.055 (1.4)	PEEK Tip	N/A	2004532	2004194	2006024	288185
Wide Pattern	HVLP	0.070 (1.8)	PEEK Tip	N/A	2004532	2004195	2006024	289013

* Includes Elite packing, carbide needle, and carbide tip nozzle.

Needle Tips

Part	Description
24E484	0.030 in. SST Needles (pack of 5)

Hoses

Part	Description	Maximum Working Pressure psi (MPa, bar)
2005141	6 ft (1.8 m) Air Whip Hose	100 (0.7, 7.0)
2006034	15 ft (4.6 m) Air Hose	100 (0.7, 7.0)
2005142	25 ft (7.6 m) Air Hose	100 (0.7, 7.0)
2006035	50 ft (15.2 m) Air Hose	100 (0.7, 7.0)
2005146	6 ft (1.8 m) Fluid Whip Hose	300 (2.1, 21)
2006036	15 ft (4.6 m) Fluid Hose	300 (2.1, 21)
2005147	25 ft (7.6 m) Fluid Hose	300 (2.1, 21)
2006037	50 ft (15.2 m) Fluid Hose	300 (2.1, 21)
2006234	25 ft (7.6 m) Air and Fluid Hose Bundle	---

Fluid Caps

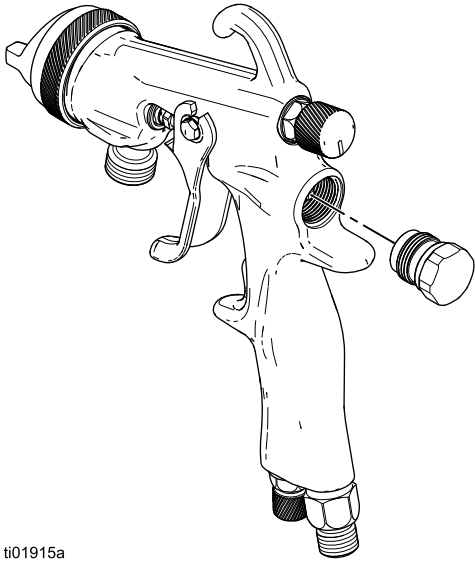

ti01915a

FIG. 32: Pressure Cap

Part	Description
2006039	Fluid Assembly Kit (non-adjustable)

Test Gauges

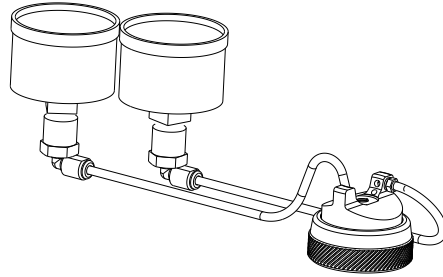

FIG. 33: Test Gauge (2006119 shown)

Part	Description
2006119	HVLP Automotive Verification
2006120	HVLP General Metal 0.5-1.8 mm (0.020-0.070 in.) Verification
2006122	HVLP Stain Verification
2006123	HVLP Waterborne Verification
2006124	HVLP High Wear 1.8-2.2 mm (0.070-0.086 in.) Verification
2006125	HVLP High Wear 0.086
2006126	HVLP General 0.086
2006127	HVLP General 0.110
2006128	HVLP Wide Pattern
2006249	HVLP High Solid

Light-Weight Lubricant

Recommended lubricant for fluid seals and wear areas.

Part	Description
111265	Sanitary, non-silicone lubricant: 4 oz (113g)

Air Valves and Regulators

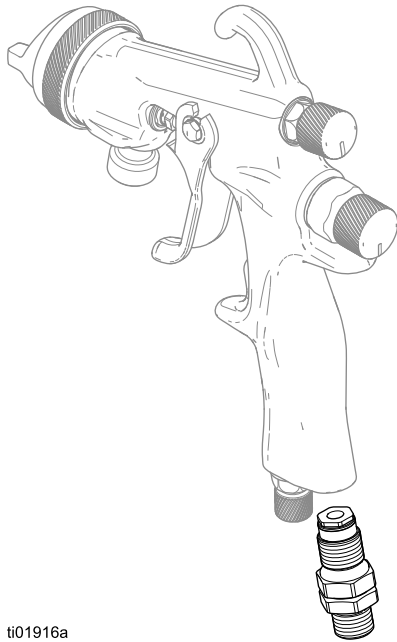

ti01916a

FIG. 34: Swivel Air Valve

Part	Description	Maximum Working Pressure psi (MPa, bar)
234784	Air Control Valve with Gauge	160 (1.1, 11)
235119	Gun Air Regulator Assembly	150 (1.0, 10.3)
239655	Swivel Air Valve	100 (0.7, 7.0)

Cups



ti01914a

FIG. 35: Fluid Cup

Part	Description
239803	1 qt SST Pressure Cup with Double Air Regulator
239804	1 qt SST Pressure Cup with Remote Air Regulator
240266*	Disposable Polyethylene Cup Liners (40 pack)
235117	2 qt Pressure Cup with Regulator and Hose

* For 1 qt siphon and pressure cups only.

Technical Specifications

Stellair Air Spray Guns	US	Metric
Maximum working fluid pressure	300 psi	2.1 MPa, 21 bar
Maximum working air pressure	100 psi	0.7 MPa, 7 bar
Maximum fluid temperature	109°F	43°C
Air inlet size	1/4 in. NPS(m) (R1/4-19)	
Fluid inlet size	3/8 in. NPS(m) (R3/8-19)	
Wetted parts	Stainless Steel, Carbide, Ultra High Molecular Weight Polyethylene, Chemically Resistant Fluoroelastomer, Engineered Plastic, PTFE, Polyamide	
Weight	1 lb	410 g

Sound Data

Conventional	
Measured at 43 psi (0.30 MPa, 3.0 bar) input pressure to the gun	
Sound Level	84 dBa
Sound Power Level	101 LwA
HVLP	
Measured at 20 psi (0.14 MPa, 1.4 bar) inlet to the gun	
Sound Level	81 dBa
Sound Power Level	98 LwA
Compliant	
Measured at 29 psi (0.20 MPa, 2.0 bar) inlet to the gun	
Sound Level	82 dBa
Sound Power Level	98 LwA
<i>Sound power measured per ISO 3744.</i>	

Air Consumption Data

Air Cap	Spray Type	Air Inlet Pressure psi (MPa, bar)	Air Consumption SCFM
General Industry	HVLP	19 (0.13, 1.3)	8.1
General Industry	Compliant	29 (0.2, 2.0)	9.8
General Industry	Conventional	36 (0.25, 2.5)	10.8
Wide	HVLP	24 (0.17, 1.7)	10.8
Trim	HVLP	14 (0.1, 1.0)	4.7
Automotive	HVLP	29 (0.2, 2.0)	14.4
Automotive	Compliant	35 (0.24, 2.4)	11.2
Automotive	Conventional	36 (0.25, 2.5)	12.6
Wood	HVLP	22 (0.15, 1.5)	14.8
Wood	Conventional	35 (0.24, 2.4)	15.2
Adhesive	Conventional	21 (0.14, 1.4)	11.7
Splatter	HVLP	---	---
Air Brush	Conventional	20 (0.14, 1.4)	2.7
Waterborne	HVLP	20 (0.14, 1.4)	15
Waterborne	Compliant	23 (0.16, 1.6)	13.1
Waterborne	Conventional	36 (0.25, 2.5)	12.6
High Solids	HVLP	19 (0.13, 1.3)	0.0
High Solids	Compliant	25 (0.17, 1.7)	0.0
High Solids	Conventional	35 (0.24, 2.4)	12.0

California Proposition 65

CALIFORNIA RESIDENTS

 **WARNING:** Cancer and reproductive harm – www.P65warnings.ca.gov.

Graco Standard Warranty

Graco warrants all equipment referenced in this document which is manufactured by Graco and bearing its name to be free from defects in material and workmanship on the date of sale to the original purchaser for use. With the exception of any special, extended, or limited warranty published by Graco, Graco will, for a period of twelve months from the date of sale, repair or replace any part of the equipment determined by Graco to be defective. This warranty applies only when the equipment is installed, operated and maintained in accordance with Graco's written recommendations.

This warranty does not cover, and Graco shall not be liable for general wear and tear, or any malfunction, damage or wear caused by faulty installation, misapplication, abrasion, corrosion, inadequate or improper maintenance, negligence, accident, tampering, or substitution of non-Graco component parts. Nor shall Graco be liable for malfunction, damage or wear caused by the incompatibility of Graco equipment with structures, accessories, equipment or materials not supplied by Graco, or the improper design, manufacture, installation, operation or maintenance of structures, accessories, equipment or materials not supplied by Graco.

This warranty is conditioned upon the prepaid return of the equipment claimed to be defective to an authorized Graco distributor for verification of the claimed defect. If the claimed defect is verified, Graco will repair or replace free of charge any defective parts. The equipment will be returned to the original purchaser transportation prepaid. If inspection of the equipment does not disclose any defect in material or workmanship, repairs will be made at a reasonable charge, which charges may include the costs of parts, labor, and transportation.

THIS WARRANTY IS EXCLUSIVE, AND IS IN LIEU OF ANY OTHER WARRANTIES, EXPRESS OR IMPLIED, INCLUDING BUT NOT LIMITED TO WARRANTY OF MERCHANTABILITY OR WARRANTY OF FITNESS FOR A PARTICULAR PURPOSE.

Graco's sole obligation and buyer's sole remedy for any breach of warranty shall be as set forth above. The buyer agrees that no other remedy (including, but not limited to, incidental or consequential damages for lost profits, lost sales, injury to person or property, or any other incidental or consequential loss) shall be available. Any action for breach of warranty must be brought within two (2) years of the date of sale.

GRACO MAKES NO WARRANTY, AND DISCLAIMS ALL IMPLIED WARRANTIES OF MERCHANTABILITY AND FITNESS FOR A PARTICULAR PURPOSE, IN CONNECTION WITH ACCESSORIES, EQUIPMENT, MATERIALS OR COMPONENTS SOLD BUT NOT MANUFACTURED BY GRACO. These items sold, but not manufactured by Graco (such as electric motors, switches, hose, etc.), are subject to the warranty, if any, of their manufacturer. Graco will provide purchaser with reasonable assistance in making any claim for breach of these warranties.

In no event will Graco be liable for indirect, incidental, special or consequential damages resulting from Graco supplying equipment hereunder, or the furnishing, performance, or use of any products or other goods sold hereto, whether due to a breach of contract, breach of warranty, the negligence of Graco, or otherwise.

FOR GRACO CANADA CUSTOMERS

The Parties acknowledge that they have required that the present document, as well as all documents, notices and legal proceedings entered into, given or instituted pursuant hereto or relating directly or indirectly hereto, be drawn up in English. Les parties reconnaissent avoir convenu que la rédaction du présente document sera en Anglais, ainsi que tous documents, avis et procédures judiciaires exécutés, donnés ou intentés, à la suite de ou en rapport, directement ou indirectement, avec les procédures concernées.

Graco Information

For the latest information about Graco products, visit www.graco.com.

For patent information, see www.graco.com/patents.

TO PLACE AN ORDER, contact your Graco distributor or call to identify the nearest distributor.

Toll Free Phone Number: 1-800-328-0211

All written and visual data contained in this document reflects the latest product information available at the time of publication. Graco reserves the right to make changes at any time without notice.

Original instructions. This manual contains English. MM 3B0141

Graco Headquarters: Minneapolis

International Offices: Belgium, China, Japan, Korea

GRACO INC. AND SUBSIDIARIES • P.O. BOX 1441 • MINNEAPOLIS MN 55440-1441 • USA
Copyright 2024, Graco Inc. All Graco manufacturing locations are registered to ISO 9001.

www.graco.com
Revision D, August 2024